

Motivation

Denoising for dynamic medical imaging

- Fast imaging, e.g., EPI \rightarrow low SNR
- complex noise statistics
- Motion between frames

Exploring similarity of images at different time frames

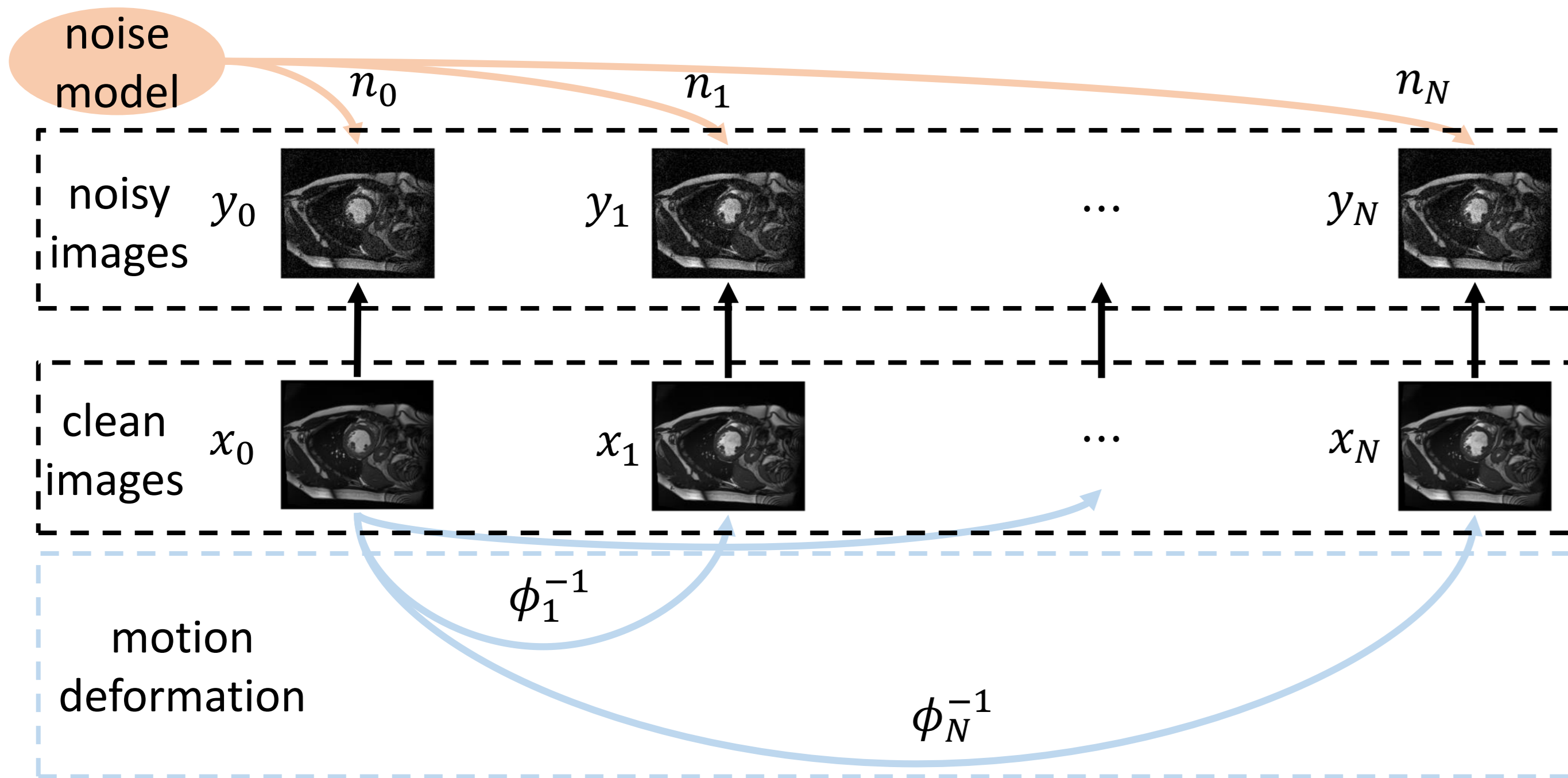

Method

Single-image denoising

- Improve the image quality using internal information of each slice
- Blind spot technique with dropout (Self2Self): denoising by training the network to recover the masked pixels

Image registration

- Deformable registration between the target frame and the other frames

Multi-image denoising

- Aggregate information from different slices

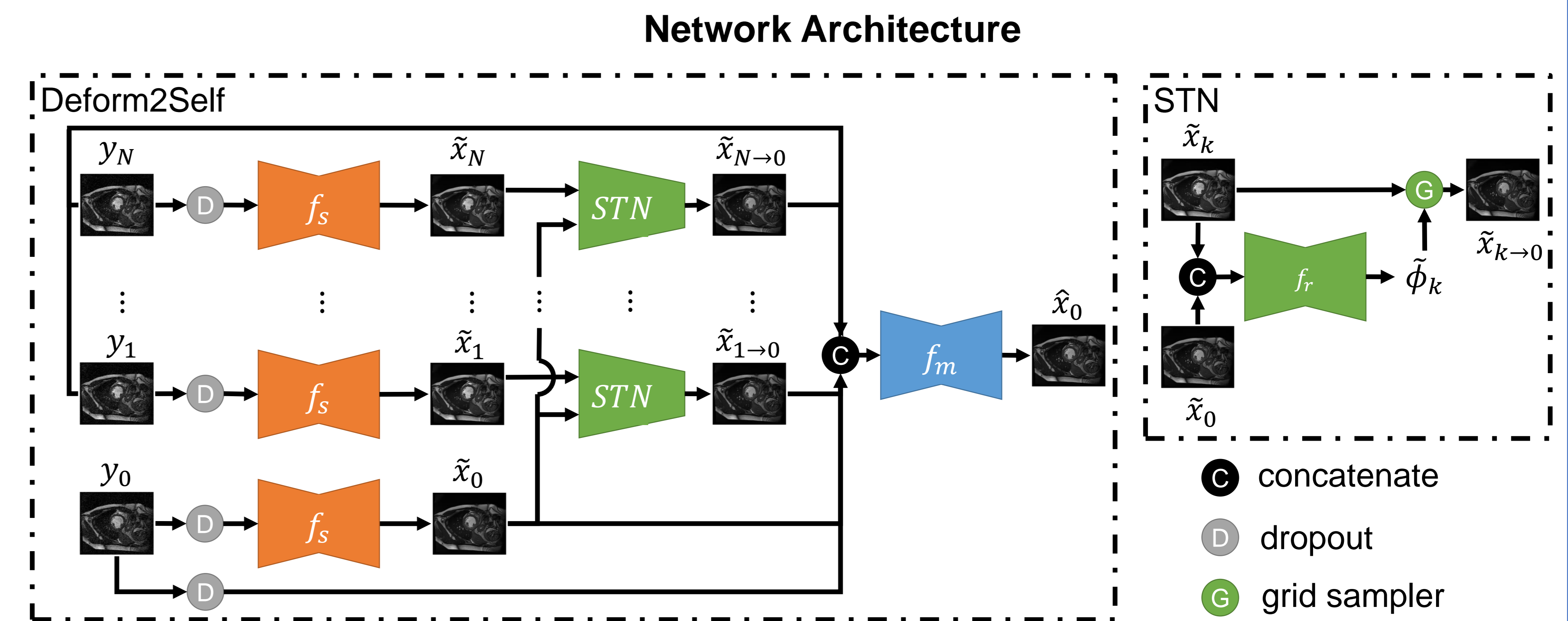

Training and loss functions

- Train the model on each series
- Self supervised learning
- End-to-end optimization
- $L = L_s + L_r + L_m + L_s$

$$L_s = \frac{1}{N+1} \sum_{k=0}^N \|(1-b_k) \odot (\tilde{x}_k - y_k)\|_2^2$$

$$L_r = \frac{1}{N} \sum_{k=1}^N \|\tilde{x}_{k \rightarrow 0} - \tilde{x}_0\|_2^2 + \lambda \|\nabla \tilde{\phi}_k\|_2^2$$

$$L_m = \|(1-b) \odot (\hat{x}_0 - y_0)\|_2^2$$

Results

PINCAT

Method	Gaussian						Poisson					
	$\sigma = 15\%$		$\sigma = 20\%$		$\sigma = 25\%$		$P = 40$		$P = 20$		$P = 10$	
	PSNR	SSIM	PSNR	SSIM	PSNR	SSIM	PSNR	SSIM	PSNR	SSIM	PSNR	SSIM
Noisy	16.55	0.300	14.05	0.208	12.11	0.151	22.42	0.603	19.40	0.472	16.19	0.346
BM3D	29.97	0.918	27.98	0.881	26.38	0.843	32.56	0.954	30.38	0.930	27.63	0.890
VBM4D	31.36	0.936	29.65	0.913	28.28	0.886	32.35	0.953	29.92	0.930	27.65	0.899
DIP	28.28	0.879	26.85	0.837	24.63	0.759	31.96	0.949	30.99	0.935	26.54	0.868
S2S	30.27	0.928	28.04	0.900	27.68	0.883	33.05	0.962	31.25	0.951	30.55	0.939
D2S	31.77	0.946	30.14	0.919	29.10	0.891	35.13	0.978	33.74	0.969	31.67	0.951

ACDC

Method	Gaussian						Rician					
	$\sigma = 5\%$		$\sigma = 10\%$		$\sigma = 15\%$		$\sigma = 5\%$		$\sigma = 10\%$		$\sigma = 15\%$	
	PSNR	SSIM	PSNR	SSIM	PSNR	SSIM	PSNR	SSIM	PSNR	SSIM	PSNR	SSIM
Noisy	26.02	0.769	20.00	0.518	16.48	0.369	25.70	0.742	19.66	0.513	16.07	0.368
BM3D	32.32	0.953	28.54	0.905	26.45	0.860	29.58	0.874	23.69	0.777	19.78	0.689
VBM4D	32.54	0.957	28.96	0.911	26.88	0.863	29.79	0.879	23.94	0.791	19.93	0.707
DIP	26.95	0.875	25.55	0.815	23.48	0.718	26.10	0.811	22.76	0.736	19.10	0.629
S2S	30.41	0.942	28.45	0.912	26.90	0.880	28.28	0.861	23.51	0.784	19.73	0.709
D2S	32.16	0.960	30.26	0.936	28.22	0.887	29.37	0.879	24.25	0.812	20.20	0.743

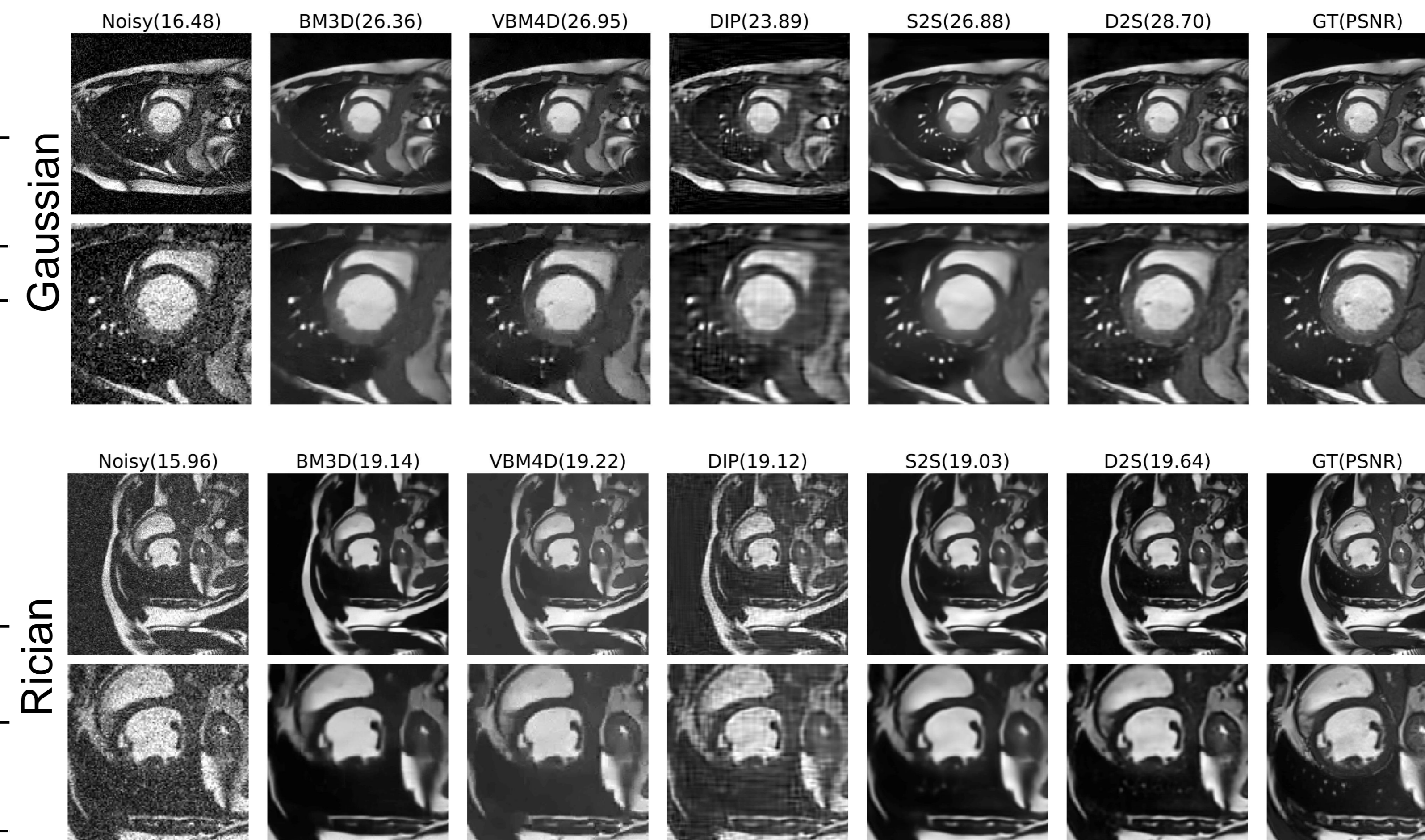

Ablation study

Method	Gaussian		Rician	
	ROI-PSNR	ROI-SSIM	ROI-PSNR	ROI-SSIM
D2S	28.01	0.894	27.55	0.889
w/o single-image denoising	27.81	0.888	27.34	0.884
w/o image registration	27.68	0.887	27.24	0.883

Conclusion

- We proposed Deformed2Self, a self-supervised deep learning method for dynamic imaging denoising.
- It explores the similarity of image content at different time frames
- Single- and multi-image denoising networks are combined to improve the image quality
- Experiments on a variety of noise settings show that our method has comparable or even better performance than other state-of-the-art unsupervised or self-supervised denoising methods.